

# GENERAL ASSEMBLY INSTRUCTIONS FOR MODERN LOG CABIN GARAGE WITH STEEL ROOF AND SECTIONAL DOOR

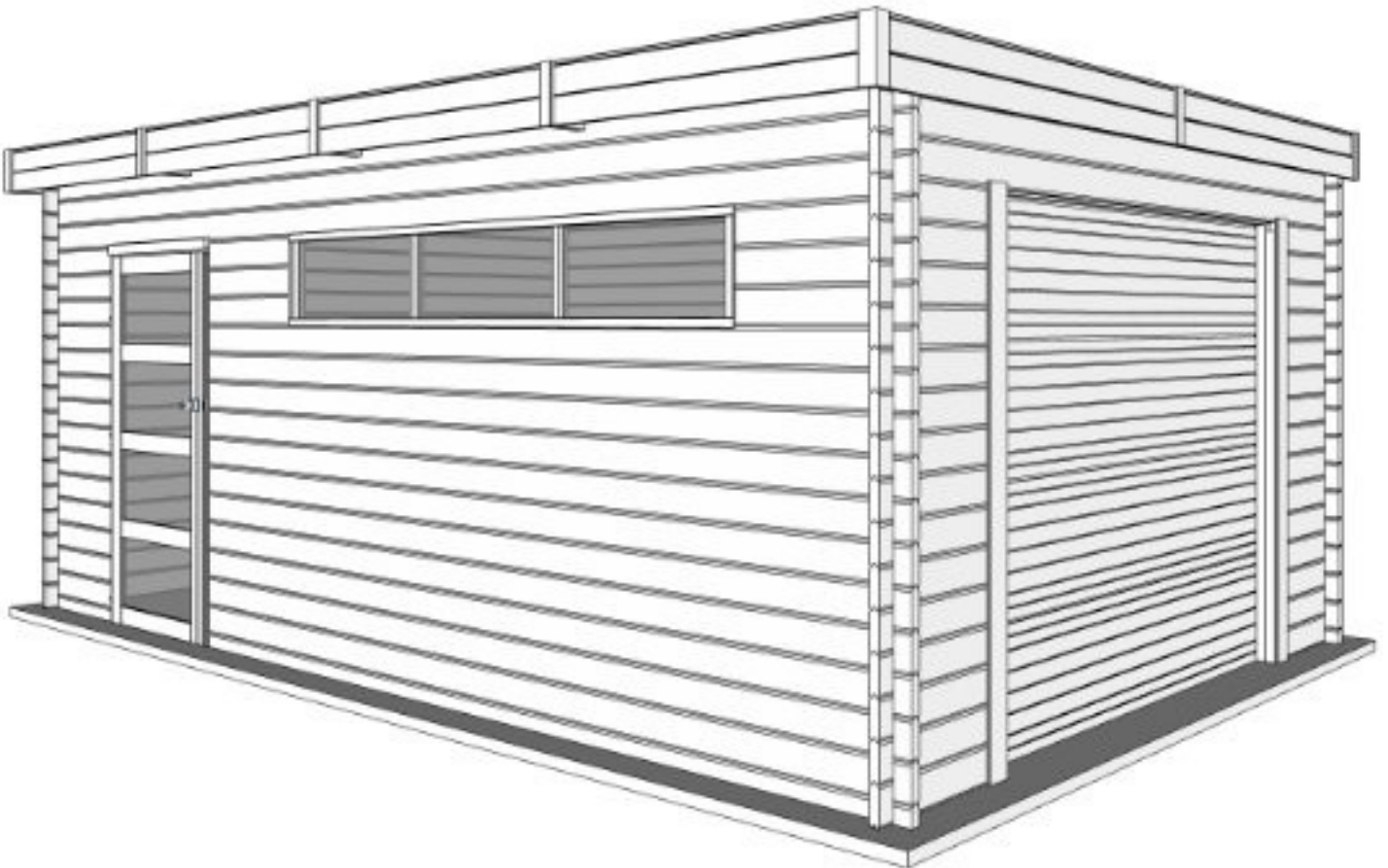

## **WOODLANDS**

QUALITY CABINS



# GENERAL ASSEMBLY INSTRUCTIONS FOR MODERN GARAGE WITH STEEL ROOF

Congratulations on the purchase of your garage.

If you read the assembly instructions carefully, you will enjoy your purchase for many years to come.

## IMPORTANT!

Before you start assembly, we would like to give you some important information that deserves your attention.

**A** You have purchased a garage made from an untreated natural product. The wood still needs to be treated to ensure a long lifespan. It is best to seek advice from a specialist in this field when choosing your treatment product and maintaining your garage. Only use products that penetrate the wood and protect it against moisture, wind and weather, as well as insects and fungi. Do not use products that are so viscous that they prevent a good connection between the tongue and groove and the corner joint. You only have the opportunity to treat the tongue and groove **before** assembly. It is very important to **treat all parts on all sides**. This means you must also treat **the inside of** the garage.

**B** It is best to install a waterproof concrete base that is 10 cm larger than the outer dimensions of the garage. It is extremely important that your garage is level and remains so. Please note that if your structure does not stay level after installation, gaps and deformations may occur in the garage. Ensure that ground moisture and other moisture cannot penetrate the wood by providing adequate ventilation in the garage and treating **the interior of** the garage against moisture. The bottom logs of your garage deserve extra attention, as they will be most exposed to water. Therefore, treat them with extra care. Seal the joint between the garage and its base with silicone (not included). Anchor your garage to its base (e.g. with L-brackets (not included)) to protect it from stormy weather.

**C** "Wood lives", a saying that also applies to your purchase. In concrete terms, this means that the height of the garage varies depending on the humidity. If you install vertical or horizontal structures (e.g. shelves, electrical wiring, storm braces, etc.), you must ensure that you do not impede this natural movement of the wood. If you connect the wood vertically in certain places, gaps will appear between your logs during periods of low humidity, often resulting in deformation of the garage. Do not be alarmed if you notice a gap above the door and window during the assembly of your garage. These are designed to accommodate shrinkage and expansion. We supply matching cover strips to conceal this gap.

**D** Remove the parts of your garage from their packaging two days before assembly. This allows the wood to acclimatise to the humidity. Place the logs slightly apart, sheltered from rain and sun. Now carry out a full check using the enclosed parts list. Complaints about materials will not be accepted if the parts have been painted. Complaints must be submitted to us no later than 8 days after delivery.

**E** Wood is a natural product. This means that slight variations may occur. What are **acceptable** variations?

- Knots,
- Fallen knots no larger than a thumb,
- Fallen knots or slight damage to the edges (tongue and groove) if coverage is guaranteed during assembly,
- Discolouration in the wood,
- Straight cracks that do not split the log, splitting cracks no longer than 12 cm,
- Resin pockets of max. 5 cm,
- Wood that is slightly bowed, if assembly is still possible (the pressure of the roof will usually keep the log straight).

**F** Ensure that your carport is **anchored** to its base (e.g. with L-brackets (not included)). Also ensure that you have effective vertical storm bracing that takes into account the tips mentioned in point C, 'Wood lives!'. Gardenas dealers sell our special storm bracing products.

**G** Do not use nails or screws when assembling the walls. The pressure of the roof with the storm bracing will ensure that your garage remains standing. To prevent splitting, we recommend that you pre-drill with a drill bit that has a smaller diameter than the diameter of the screw.

**H** If a part is damaged during assembly, or are you having trouble figuring it out? Our after-sales service is at your disposal:

- during office hours by telephone: +32 (0)52 21 95 71
- by fax: +32 (0)52 22 09 03 or
- by e-mail [sav@gardenas.be](mailto:sav@gardenas.be)
- if you notice any damage to the package, please let us know within 48 hours.

Once you have checked all parts against the accompanying parts list **and** treated them, you can start assembling. What do you need? A saw, a protractor, a piece of auxiliary wood, a screwdriver (preferably battery-powered or electric), 2 ladders, a rubber mallet, a drill, a set of spanners, silicone. You must have at least 3 adults for the assembly. Keep children away during assembly.

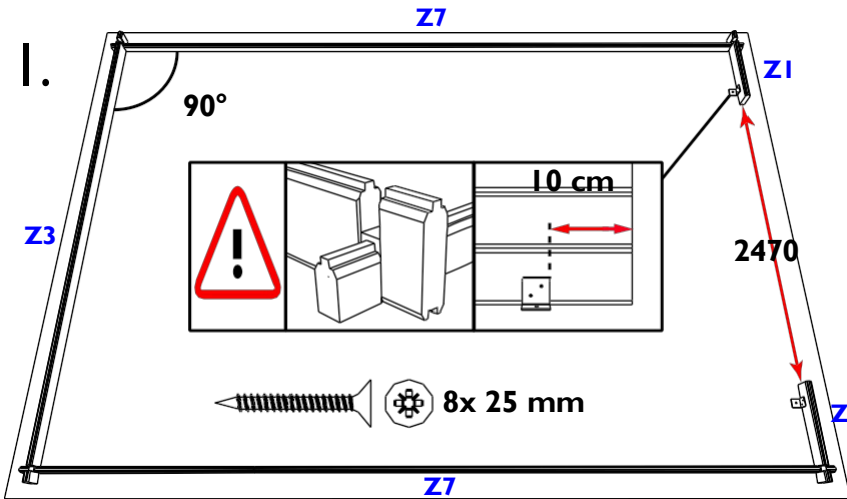

Ensure that you immediately achieve a 90° angle in your corner joint. The tongue should be at the top. The bottom logs in the front and rear walls are half boards with only a tongue, the bottom log of the side walls have tongue and groove. Ensure that the logs rest firmly on the ground. Respect the gate opening dimension of 2470 mm.

To keep your garage perfectly square, anchor the bottom log to the ground to the base at both sides, 10 cm from the door opening and on the interior, using an L-brackets (plugs not included).

Built the garage further as shown in the wall drawings from the parts list up to 3 logs high. You can choose which side to place the door on. Use a hammer to fit the logs tightly. However, never strike the wood directly (damage to the tongue can make assembly more difficult), but strike a piece of wood or use a rubber mallet.

To keep your garage square, anchor the front bottom log to the base on both sides, 5 cm from the door opening and on the interior, with L-brackets (plugs not included). Now saw the front log flush to the ground as shown in the drawing (level with the already built sections beside the door opening).

The piece you saw off is waste.

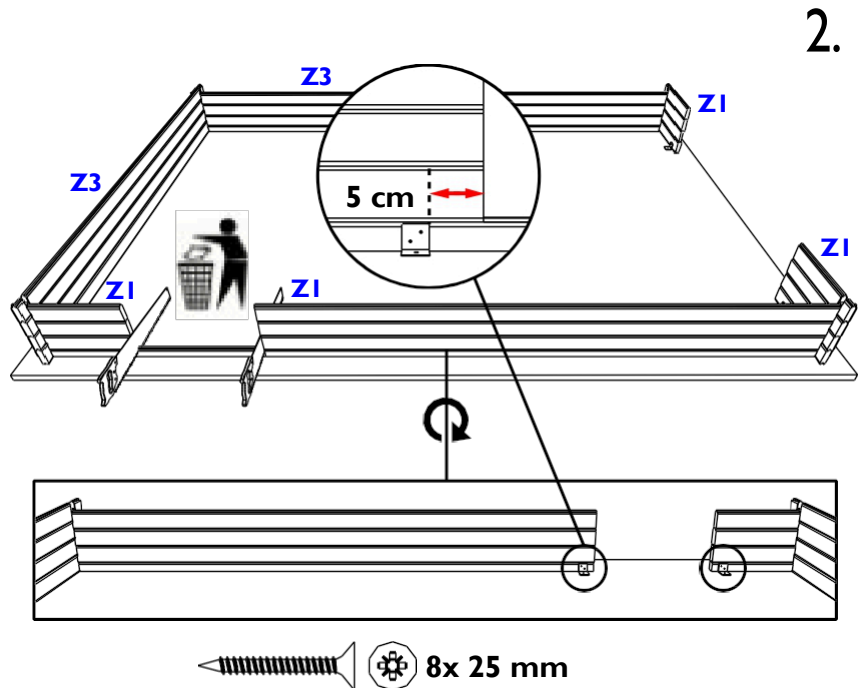

2.

Screw the hinge pin (male part of the hinges) into the pre-drilled vertical stiles (only the left stile for single door models). Lower the door frame X/EDO (3 parts still to be assembled) into the opening. Make sure that the door opens outwards. **Secure the frame only at the bottom to the garage. At the top, screw the horizontal stile to the vertical stile, never to the garage itself** (see tips and advice 'wood lives'). Finish the door once the entire garage is fully assembled.

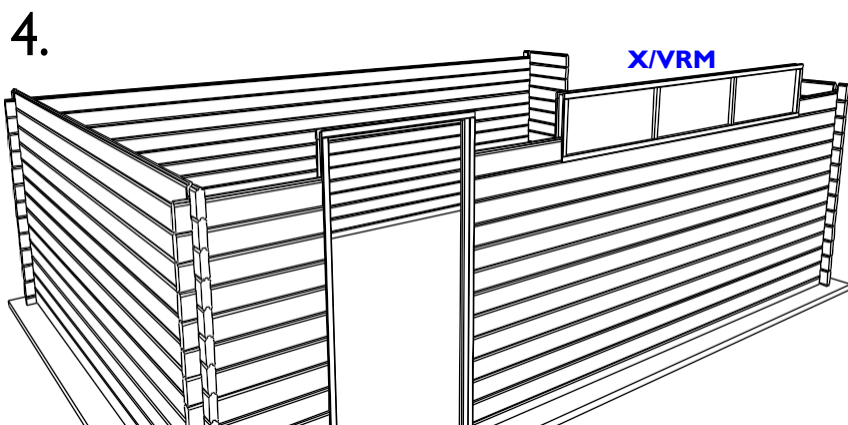
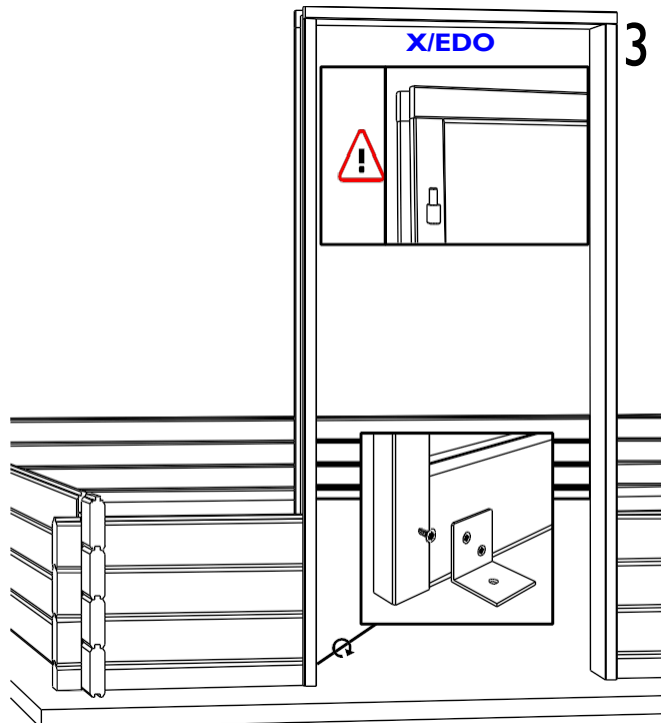

Continue building according to the supplied drawings (see detailed parts list) until you reach the bottom of the windows. Now add one more layer. Lower the window frame X/VRM into the opening. **Do not attach the frame to your garage with screws or nails!** ("Wood lives").

Continue building as indicated in the wall drawings from the parts list until you need to place the gable on the side walls.

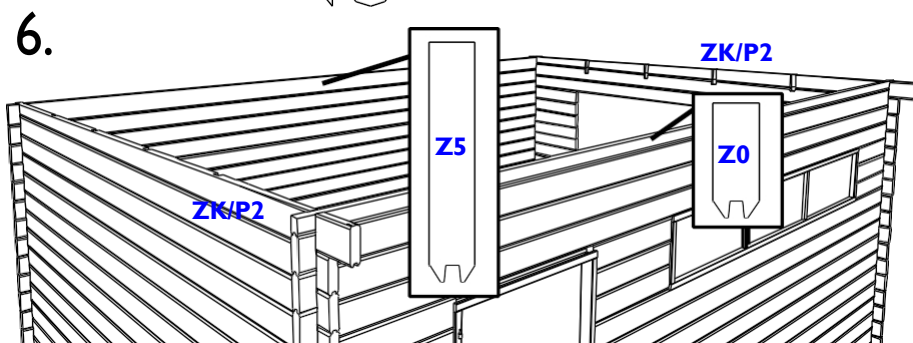
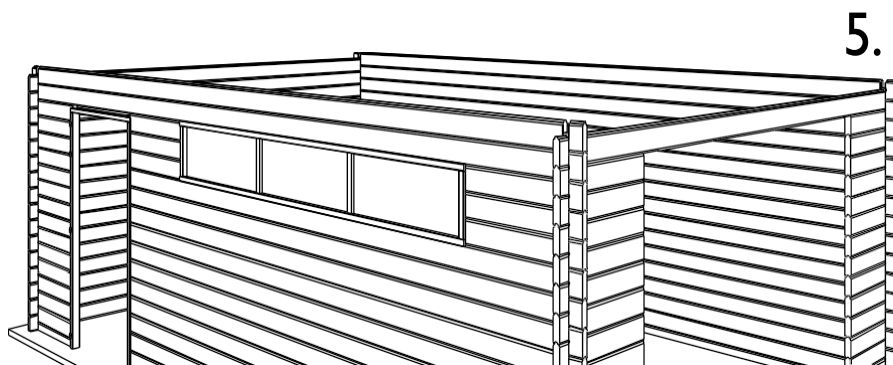

Continue building as shown in the wall drawings from the parts list. Use two 70 mm screws to anchor the various parts of the ZK/P2 roof gables together. Ensure neat, sloping edges. The cutouts on the inside. The top log of the front and rear walls has no tongue, only a groove; in other words, it is flat at the top.

  10x 70 mm

7.

Place the roof rafters P2 in the cutouts of the roof gables. Secure each rafter through the gable with one 70 mm screw per rafter per side.

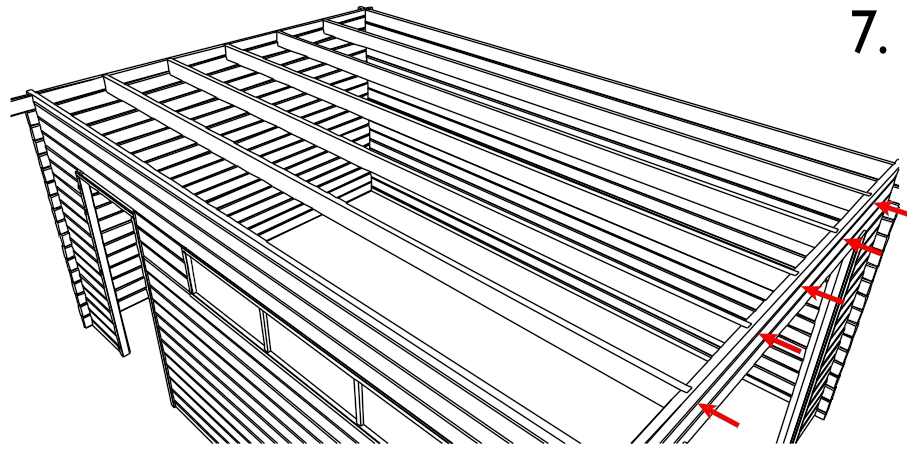

8

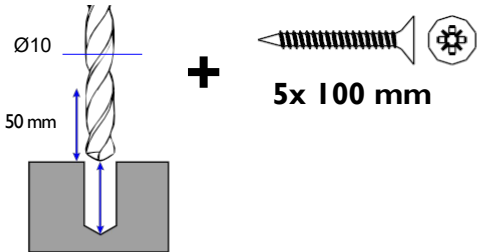

Fasten the 2 cross beams S/045/095/3620 to each other with 5 screws of 100 mm. Pre-drill the top beam with a Ø10 mm drill bit, 50 mm deep.

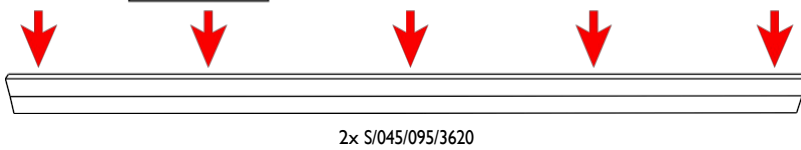

9.

  8x 100 mm

Mount the assembled cross beam in the centre of the depth of the garage against the underside of the roof rafters. Secure with 8 screws of 100 mm through the walls.

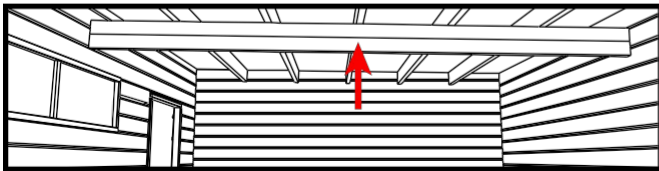
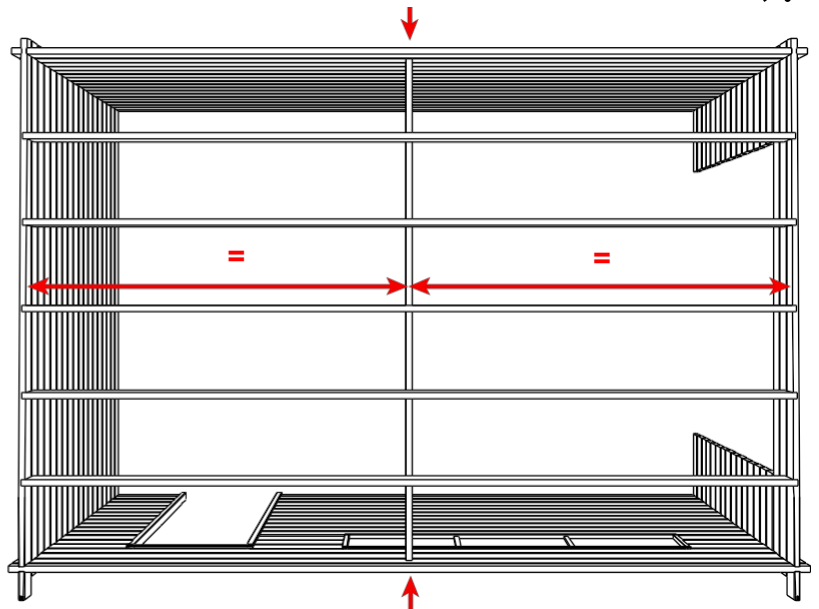

10.

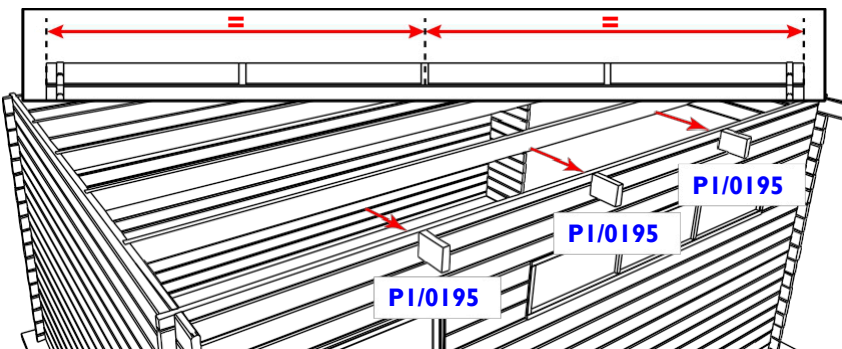

Screw the auxiliary roof rafters P1/0195 securely into the end grain of the auxiliary rafter using two 100 mm screws through the front wall. Keep the top of the auxiliary rafters level with the top of the front wall. Mount the middle auxiliary rafter perfectly centred on the front wall. Distribute the remaining auxiliary rafters symmetrically (equal distance between all auxiliary rafters).

  6x 100 mm

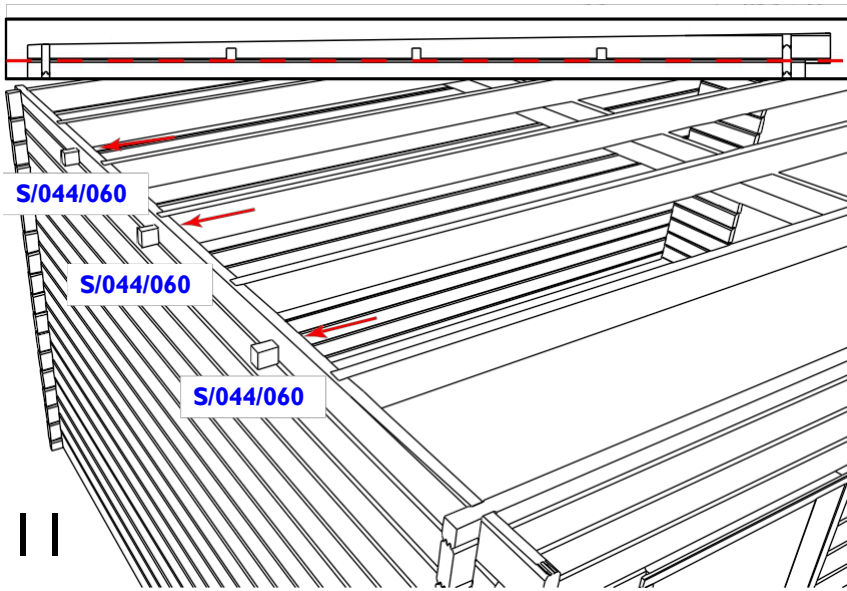

Screw the S/044/060 blocks together; each with 1 screw of 100 mm through the side wall, fixed in the end grain of the block. Keep the bottom of the block level with the bottom of the front overhang. Distribute the blocks symmetrically across the side wall.

11

Place the lateral trim battens FSLM A (with tongue) on the sides, 10 mm below the bottom of the blocks (detail A). Secure each one with two 50 mm screws to the walls and blocks. Now place the front FSLM A (in 2 parts) at the front. Align them to meet at the central auxiliary roof rafter. Screw them securely to the auxiliary roof rafters and walls. Also screw them end-grain into the side trim battens with 2 x 35 mm screws (detail B). No similar trim is provided at the rear due to potential problems with moisture.

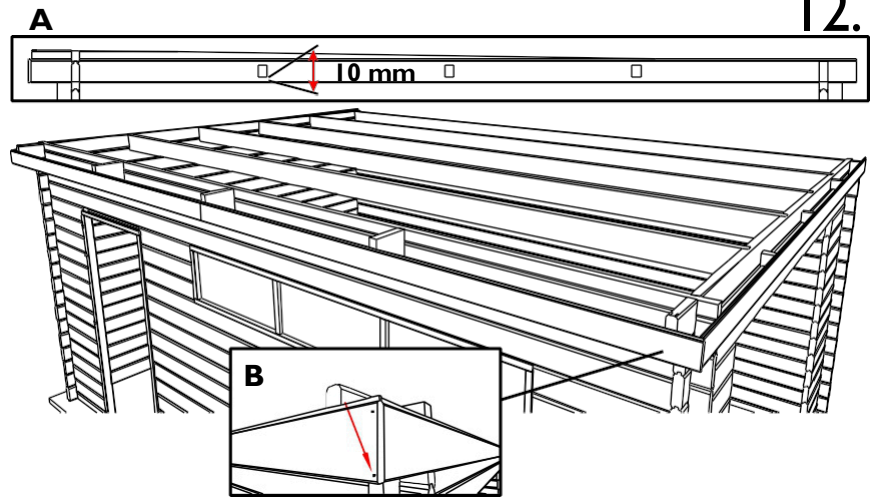

12.

13.  33x 35

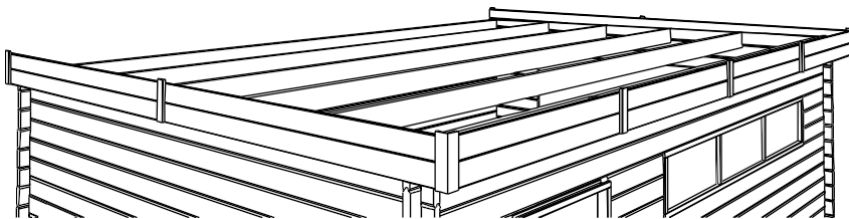

Place the lateral trim battens FSLM B (with groove) on the battens FSLM A. Connect the two types of battens at the corners with the HSL/230 strips. At the rear ends and in the middle of the facade and side walls, use the SSL/230 strips. Align the bottom of these strips level with the bottom of the FSLM A parts.

**CAUTION! Never install the roof sheets one by one, but lay them out completely first!** So first distribute all PPD IAC roof sheets over the roof before screwing them down and ensure equal spacing between the sheets to control expansion. Mark the position of the roof rafters and walls with a pencil. Ensure that the outer corrugation without anti-condensation fabric overlaps the previous sheet.

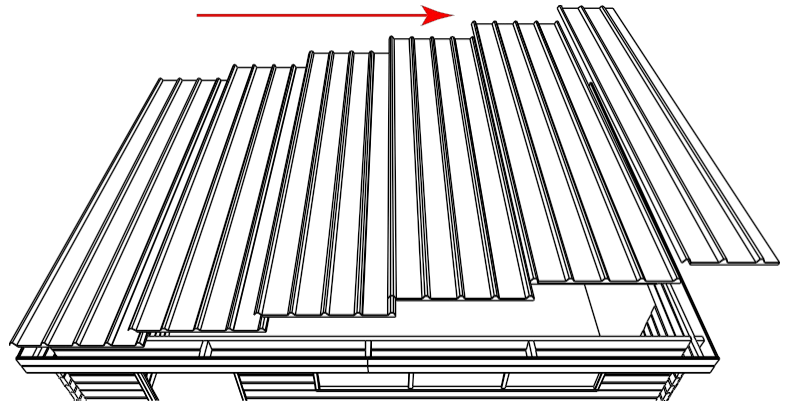

15.

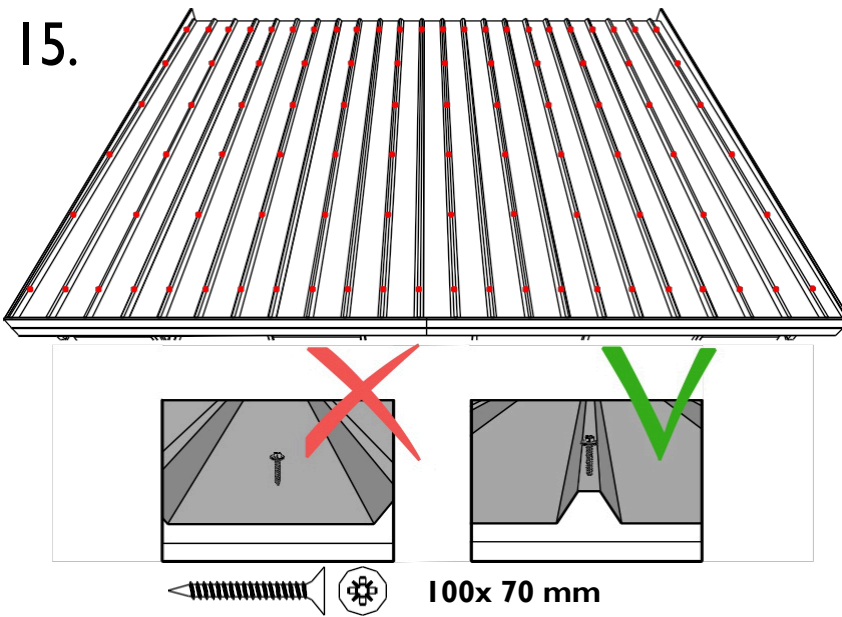

Check that the sheets are perfectly aligned. Mark the centre of the roof rafters and walls on top of the sheets, connecting the pencil marks with a long slat or string. Drill through the steel of the roof sheet with a 5 mm drill bit and remove all iron filings (risk of rust stains). **Warning!** Always drill through a corrugation and never through the flat part of the sheet. Drill every corrugation on the front and rear walls. On the roof rafters, drill where the sheets overlap, once in the centre of the sheet and once on the outside. Now screw the sheets in place using the screws with caps. Seal the joints between the sheets and the trim battens all around with silicone (not supplied).

**Warning!** Impregnate the lower part of the anti-condensation fabric, which protrudes **beyond** the rear wall, thoroughly with a clear varnish. This is to prevent the anti-condensation fabric from absorbing **water** and to prevent **moss formation**. If desired, apply a bead of silicone between the frame and the steel sheets.

Now screw the SSL45 storm battens onto the FSLM B front battens. Use 5 x 35 mm screws per batten. Start with the front ones (in 2 parts) and then do the ones on the sides. These SSL/45 battens still need to be cut to length.

16.

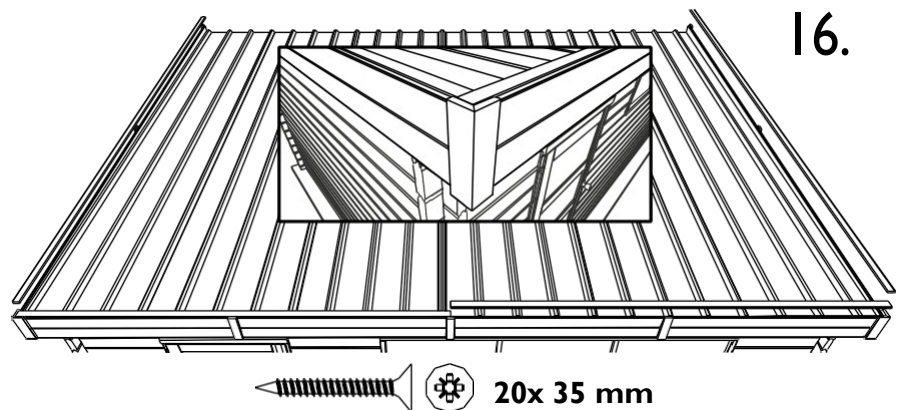

Now install the EDM04 door using the hinges supplied. Screw the hinge knuckle (female part of the hinges) into the door and hang it. By turning the hinges in or out, you can position the door leaf until it hangs straight. Please refer to the instructions for the handle-lock for mounting the handle. Provide the recess in the frame yourself to accommodate the latch bolt. Mount the strike plate and remove the visible wood with, for example, a slightly thicker drill bit or mark the opening, remove the strike plate and remove the marked part with a chisel.

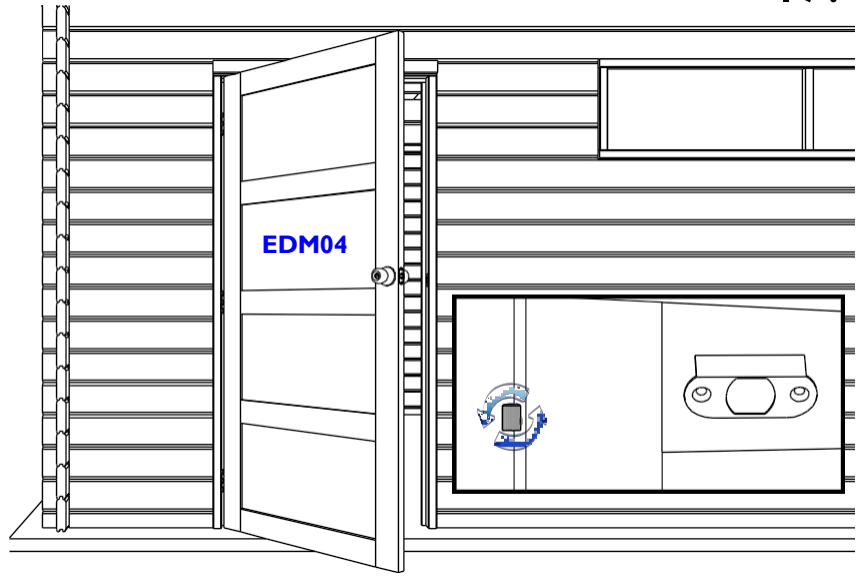

18.

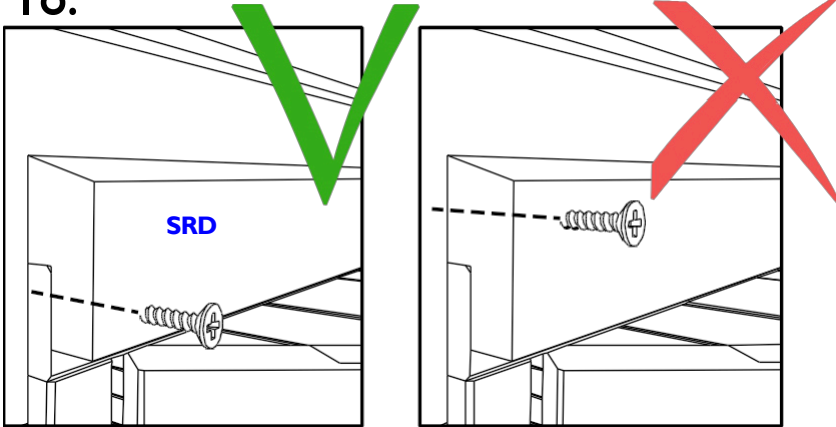

Place the SRD trim batten on top of the door frame, both inside and outside. It conceals the top gap during wood movement (see 'wood lives'). Secure it **to the door frame** with 25 mm screws. **Never secure it to the wall!**

Place the frame X/SECP01 of the large gate as indicated on the drawing. First install the 2 vertical stiles. Please note that there is a difference between the inside and outside. Then place the horizontal part. Check that everything is perfectly square before fixing the bottom with a 70 mm screw on both the left and right sides. At the top, connect the vertical and horizontal parts together using two 35 mm screws. Please note: never screw into the wall, as this will cause gaps to appear between logs over time ('wood lives'). To keep everything square, screw a block S/015/060/0070 next to and against the frame parts, using two 35 mm screws each.

19.

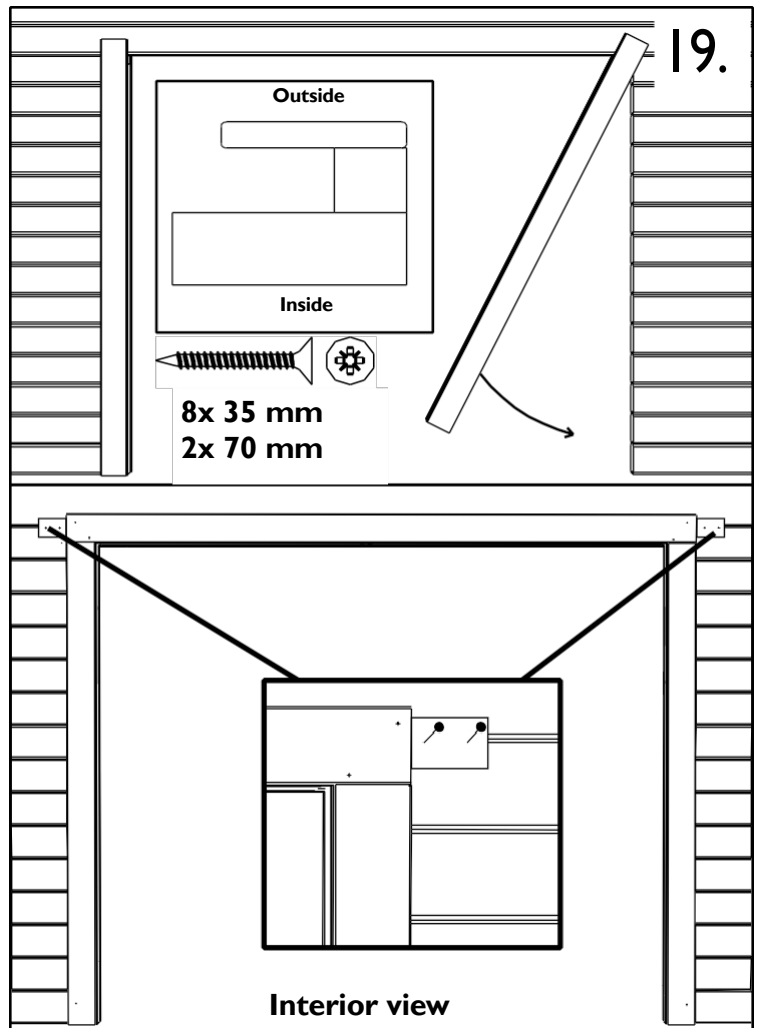



10 pcs 50 mm

20.

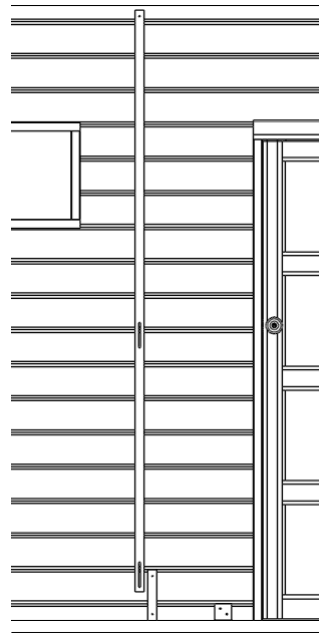

Front wall

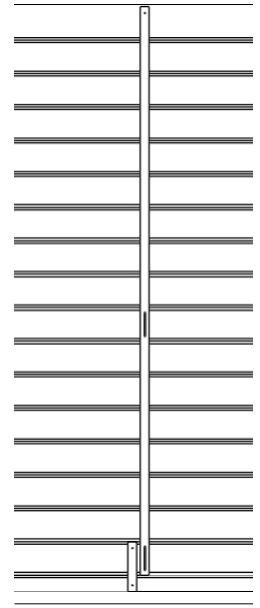

Rear wall

Place 2 strips 599931.

Do this along the interior at the bottom, between the window and door and in the middle of the rear wall. Use two 50 mm screws per strip.

Now place a 599932 strip next to each of the smaller strips. The **large recess should be at the bottom**. Secure at the top with a 50 mm screw. Place a fender washer behind the screw head.

Position centrally at mid-height and bottom, in the opening centre. Leave a slight clearance between the washer and wood for movement.

21

Seal the following areas with silicone (not included): The joint between the garage and the base on the exterior; around all glass and/or plexiglass parts.

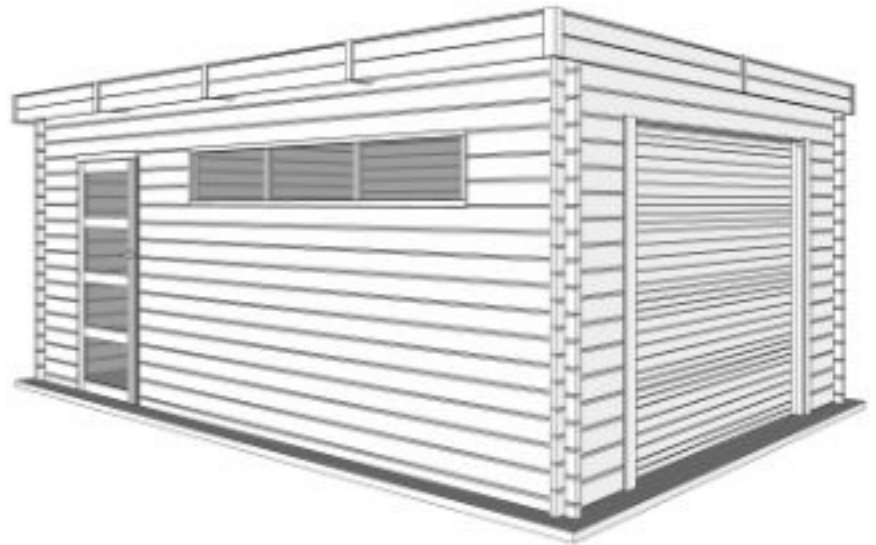

Follow the instructions for the sectional door itself. These instructions have been drawn up for different types of doors. For your door, follow the instructions marked with an \* (<50 kg and <3 m).

**Maintenance:** water, wind, snow, sun and insects are the main enemies of your garage. Consult a specialist for advice if you have any questions about products, timing, etc. for treatment.

## **WARRANTY**

The product is made of wood, a natural product that, due to its outdoor placement, will continue to "live" and therefore requires ongoing attention. Assembly, treatment and anchoring will be carried out by or on behalf of the customer. Gardenas is therefore responsible for and provides a warranty on the product and its components themselves, but not for the consequences of incorrect assembly, missing or inadequate anchoring, or incorrect or inadequate maintenance.

### **How long?**

Unless otherwise stated, Gardenas offers a 5-year warranty on its products. Fittings and roofing are covered by a 2-year warranty. Products sold as pressure-impregnated are covered by an extended 10-year warranty against rot, mould and insect damage to the wooden parts.

The warranty period starts from the date of purchase.

### **What is covered by the warranty?**

- The structural design of the product for safe and normal use.
- The correctness of the parts in terms of quantity and shape upon delivery. Any deviations must be reported no later than 14 days after delivery.
- The warranty is limited to the replacement of defective, damaged or unusable parts.

### **What is not covered by the warranty?**

- Costs of (re)installation, production, assembly, treatment.
- Parts that are no longer in their original condition.
- Defective parts that were installed anyway.
- Minor deviations from the natural material, whether or not specified in the manual, which do not compromise the stability and expected lifespan of the product (e.g. knots, cracks, discolouration, slight deformations that can be assembled and will have no impact after assembly or will be invisible after assembly, etc.).
- Damage, deformations or defects resulting from ignoring to strictly follow the advice and instructions in the product manual and/or incorrect or careless use of the product, as well as damage caused by poor foundations.
- Damage and degradation and their consequences due to inadequate treatment of the product.
- Damage caused during transport and storage, whether or not due to extreme humidity, if transport and storage were not carried out under Gardenas' management.
- Damage caused by third parties, animals, insects (except if the product was delivered pressure-impregnated) and termites.
- Natural ageing or discolouration of the product.
- Damage caused by a roof load (e.g. snow) of more than 50 kg/m<sup>2</sup>.
- Direct or indirect damage to items and materials stored in or under the product.
- Consequences of force majeure: storms, natural disasters, floods, vandalism, etc.

### **Parts availability and delivery**

Gardenas guarantees the availability of all parts or a valid alternative for each part for up to 5 years after purchase of the product, regardless of whether the part is still under warranty or not.

Gardenas will make every effort to provide any replacement parts as quickly as reasonably possible. Gardenas will deliver the parts in the same manner and to the same location as it delivered the original product.